

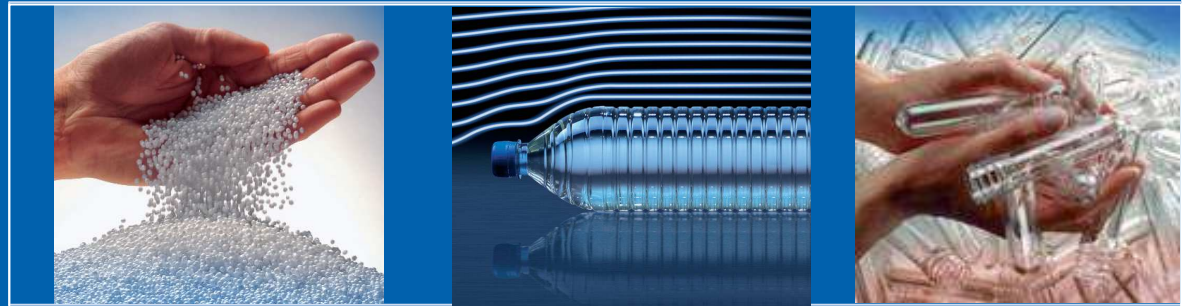

Lurgi

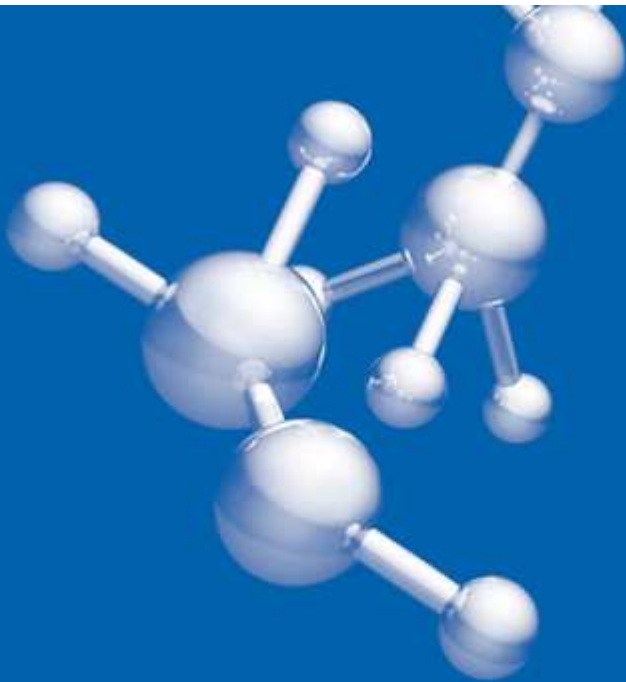

**Lurgi GmbH
Zimmer® Technologies - Polyester**

Frankfurt/M. August, 2011

Zimmer® Polymer Technologies History



- 1950 Founded by Hans J. Zimmer
- 1991 Affiliate of Lurgi Group, Germany
- 2000 Affiliate of MG Group, Germany
- 2005 Affiliate of GEA Group, Germany
- 2007 Lurgi Zimmer GmbH;
Since 2007: Lurgi GmbH, Member of Air Liquide Group



Hans J. Zimmer





Zimmer® Polymer Technologies for Polyesters and Polyamides

Packaging Resin

PET Bottle
PET Film
PA 6 Film



**Textile Filaments
Staple Fibers**

PET
PA 6
PTT



Industrial Yarns

PET
PA 6
PA 6.6



**Engineering
Plastics**

PET
PBT
PA 6



Zimmer® Polymer Technologies
Typical Production Plants



Thailand, 300 tons per day
PET Resin



Germany, 500 tons per day
PET Resin



China, 1800 tons per day
textile PET



Pakistan, 200 tons per day
textile PET



Malaysia, PA6 plant

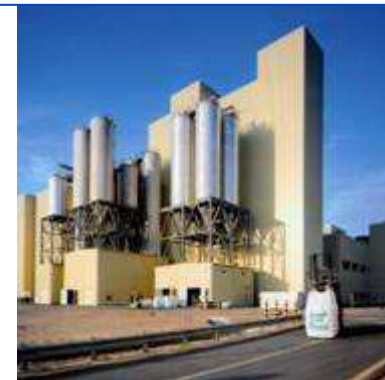

Saudi-Arabia, PET plant
4 PET Lines

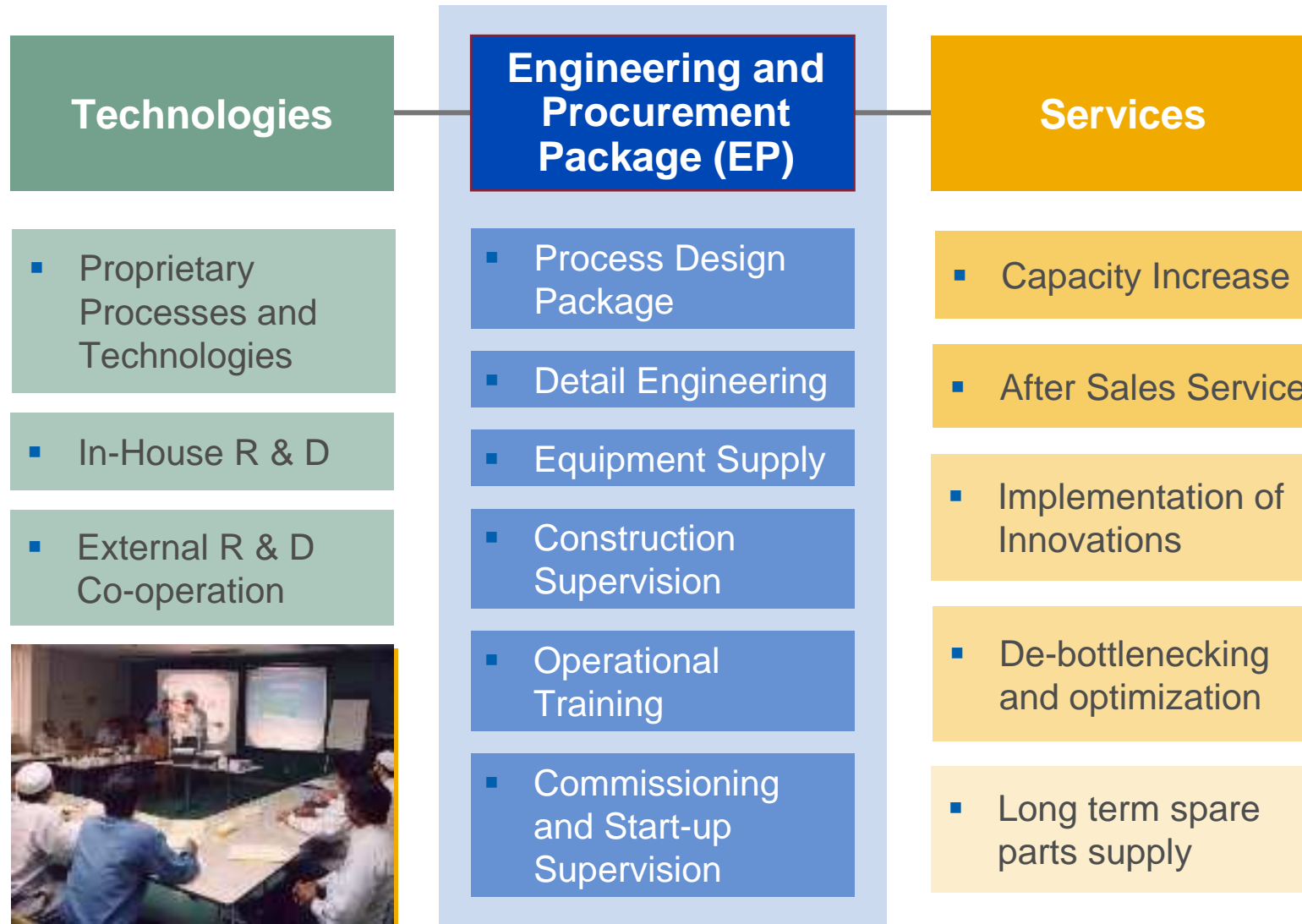



Lurgi - Zimmer Technology

- We have our own PET Know How (Technology, Reactors, Recipes, etc.)
we offer also the leading Technologies for PBT and Nylon 6
- Our R & D Activities are based on Pilot Plants
- We have built most of the PET Plants worldwide
- Latest Order-Intake:

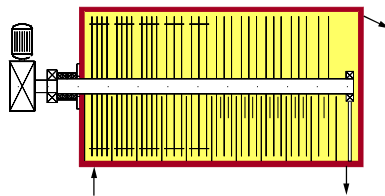

660 t/day textile grade/direct spinning
- Project Execution
2 x 660 t/day bottle grade
- Project Execution





2011
Start-up of a
400 tpd PET Line
in Canada (Revamp)

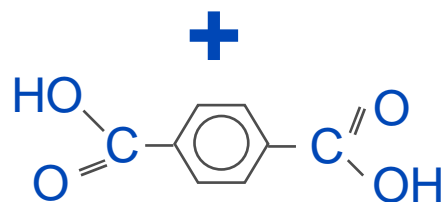

PET



Zimmer® Polymer Technologies Introduction



From: Giovanni Iadeluca <giovanni.iadeluca@selenis.ca>
To: Gerald Kriesche <Gerald.Kriesche@lurgi.com>
Date: 10.05.2011 05:23
Subject: RE: Lurgi - Zimmer Technology

400 tpd Montreal/Canada

Good morning Gerald,

I am delighted with the plant performance, please pass on our note of gratitude to your team. We are in fact running well and have been on spec without any off spec excursion. We had an external lab test our resin and it has been benchmarked as a top North American resin.

.....

kindest regards,
 Giovanni

Zimmer® Polymer Technologies Introduction – Latest Order Intake

A complex process flow diagram for a PET line, showing various units, pumps, and piping. A central image shows a large industrial reactor or spinning zone with a blue mist. To the right, a diamond-shaped callout contains the text 'Zimmer Technology' and a 3D cutaway of a spinning head assembly. The background shows a factory interior with machinery and a railing.

12/2010

**Contract signed –
660 tpd PET Line
incl.
Spinning +
4 Fiber Lines**

**Zimmer
Technology**

Zimmer® Polymer Technologies Introduction – Reference/Film Grade



31,500 tpa PET Film Plant – PET Chips

- start-up: I/2011
- PET and Copolymers/Film
- Specialities

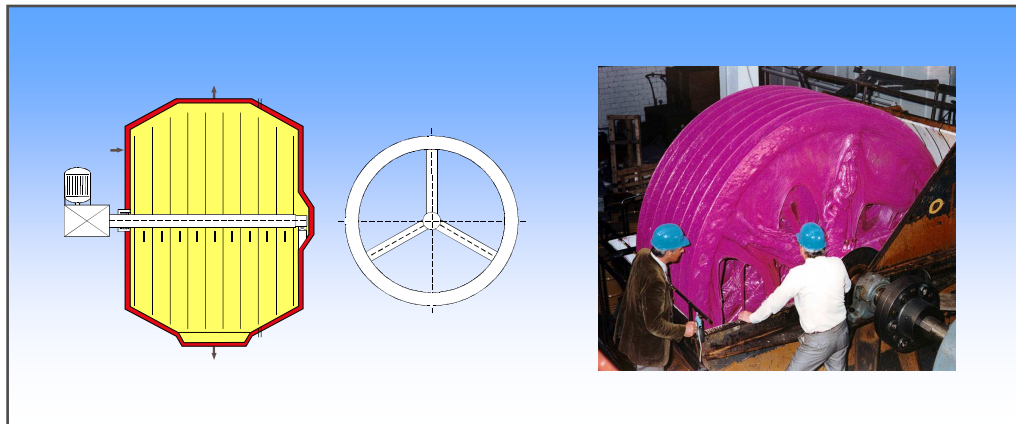

Zimmer® Polymer Technologies
Introduction – Latest Order Intake



ОАО «СИБУР-ПЭТФ»

May 2011
Revamp of a PET Plant
for the Production
of Bottle Grade Chips

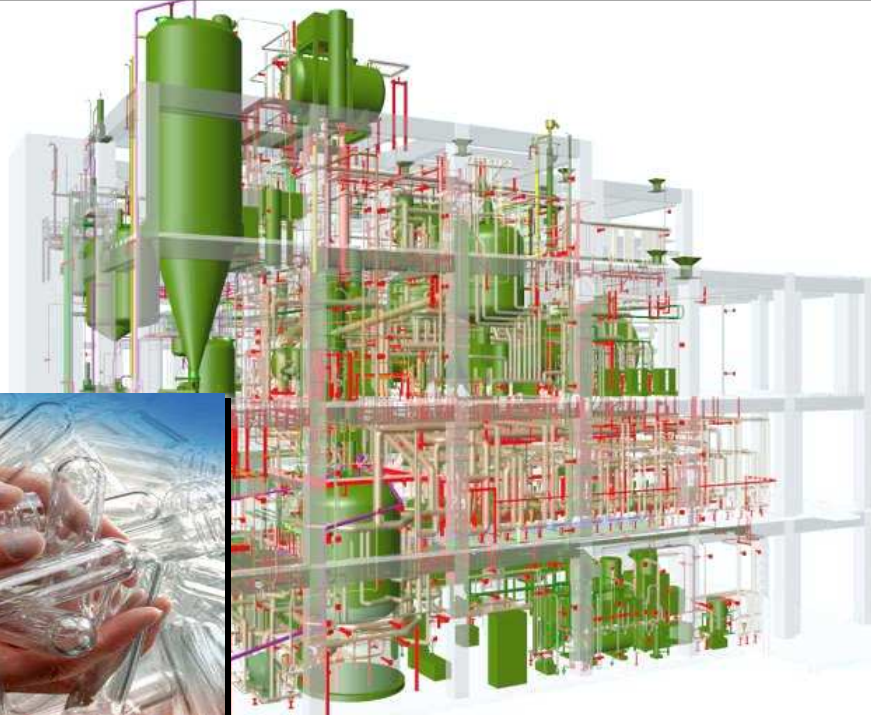



■ Zimmer has the longest history of delivering proven PET technology to satisfied customers

■ Key design factors (low temperature process, staged design, optimized residence time, advanced process control strategy) ensure market-leading performance

- High quality PET product
- Broad market acceptance
- Competitive operating costs

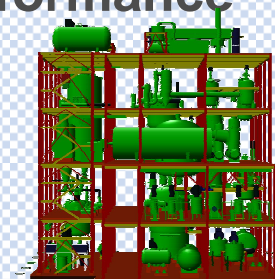

■ Additives, recipes and integrated technologies for improved product performance

■ Best available technology without competitive restrictions



Polycondensation

Why are Zimmer Technology Polycondensation Plants quick quality producers?

➡ High-quality Start-up preparation is incorporated in design

- Helium leak tests
- Vacuum standing tests
- Hot-dummy run

➡ Low temperature profile enable operator to

- Think before acting
- Easy manual operation



Results for Investment and Operation On stream Factor of Plant

■ Required time for shut down and maintenance

- shut down and cooling down of equipment for inspection	3 days
- inspection of equipment, exchange of mechanical seals	1 day
- heating-up and leak check of plant	2 days
- restart of plant	1 day
Total	7 days

Based on a shut down period of 7 days every 3 years, the yearly operation time per year is calculated to 363 days.

363 days operation per year → **On stream factor: 99.45%**



■ Standard PET Technology

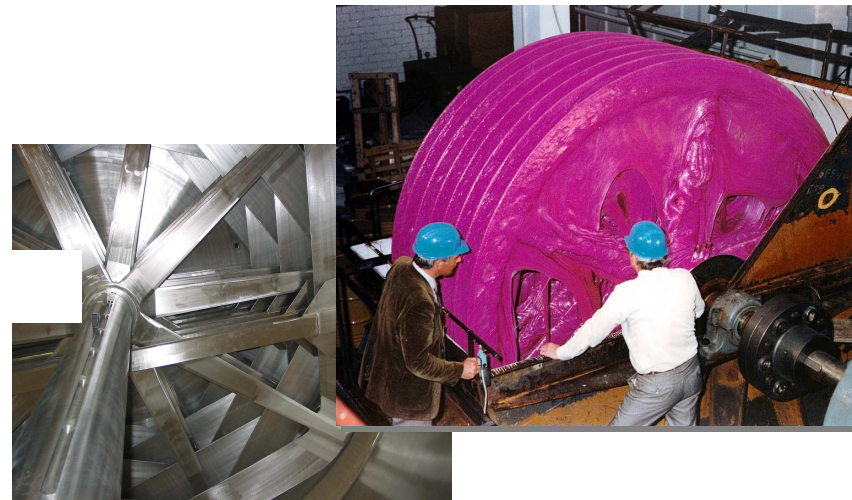
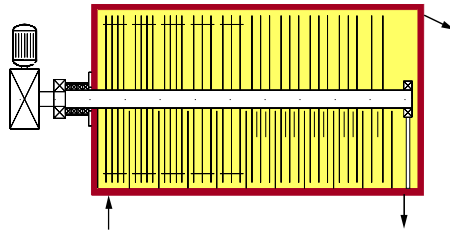



PET Concepts – standard Process with SSP

- 660 tpd – single Poly Line
 - 1,000 tpd – single Poly Line
 - 1,800 tpd – single Poly Line
- ➔ up to 2,100 tpd single Poly Line

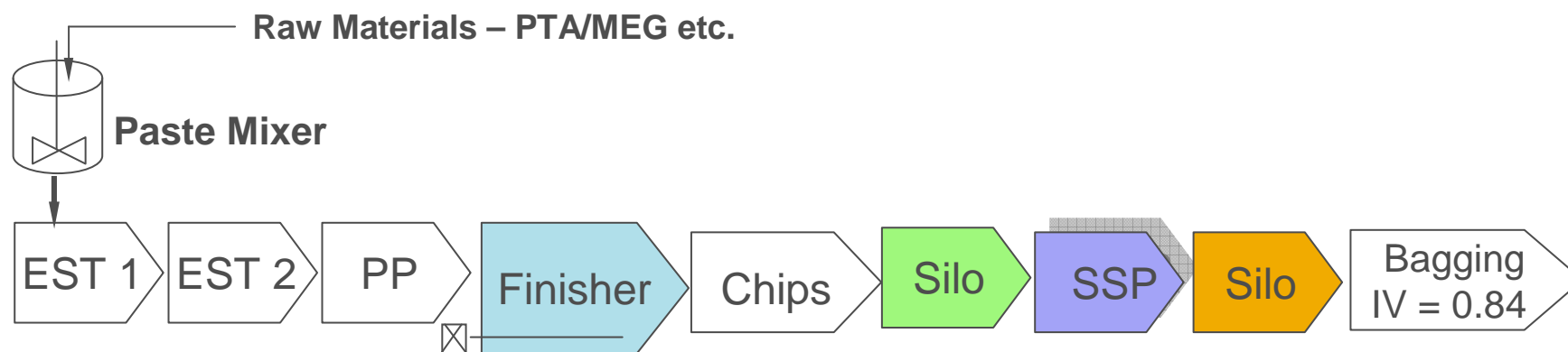



Standard Melt Plant with SSP

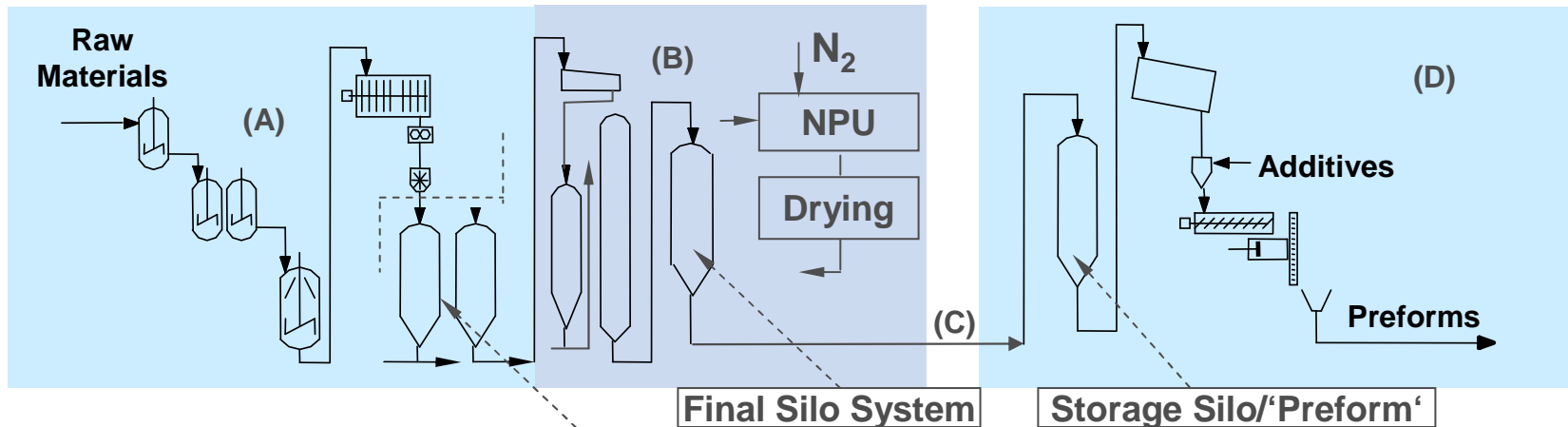

Melt plant (A) produces amorphous intermediate chips product

SSP (B) combines multi-stage crystallization with solid state polycondensation

for IV lift

Chips storage, pack-out and transport (C)

Preform plant (D) – chips storage, drying, preform machines



Design of standard PET Lines – Capacity: 660 t/day (Example)

– (bottle grade)

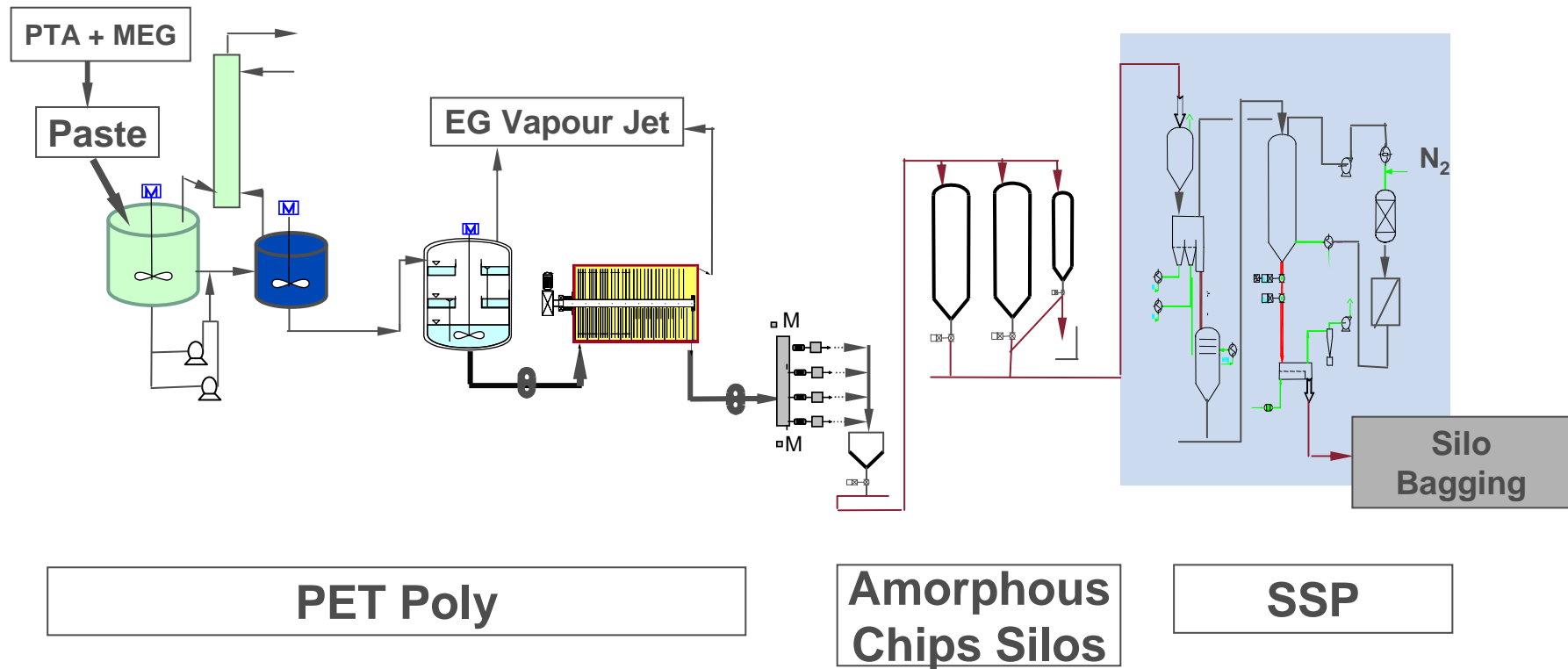

Zimmer® Polymer Technologies
Double Drive Disc Ring Reactor



Commercially proven Finisher up to 660 tpd (700 tpd)

- Bottle grade PET
- Textile grade PET

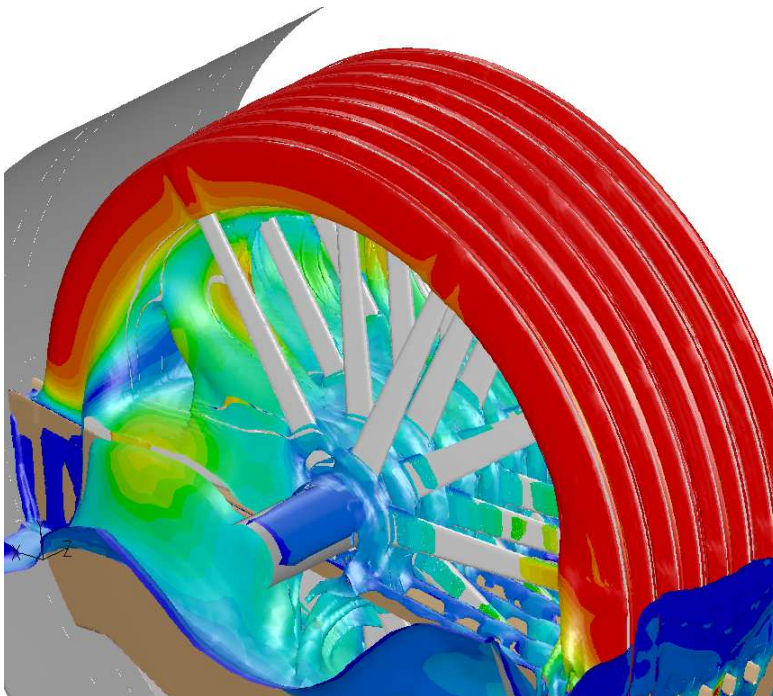

Simulation of high viscous polymer flow through the final chamber



Filming action releases the EG vapors, thereby increasing polymer melt viscosity (**film formation**)



up to 900 tpd
for
Bottle Grade

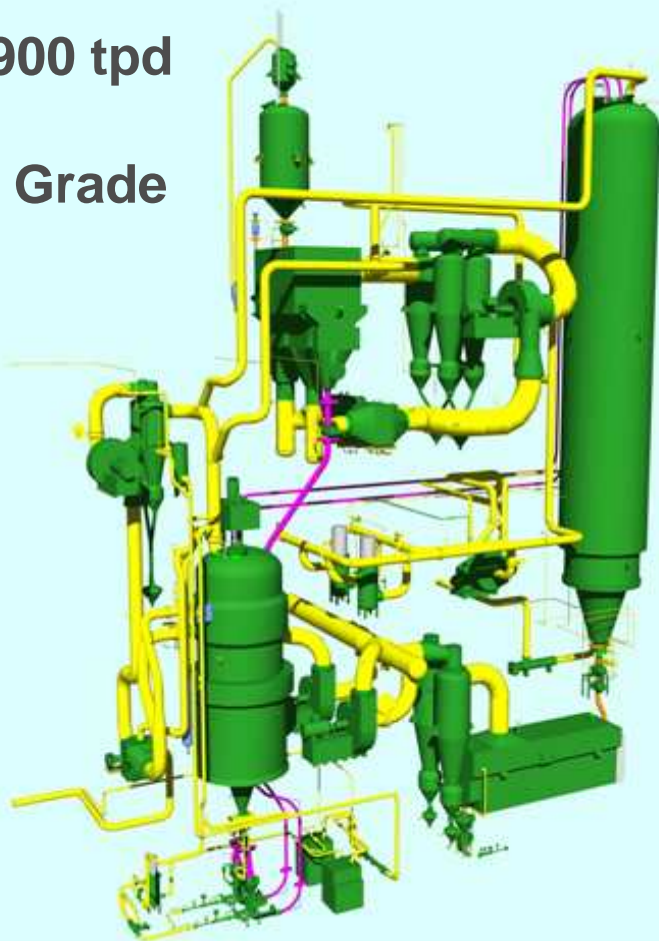

Latest Technology

- **4 Stage SSP**
 - Precrystallizer
 - Crystallizer
 - SSP Reactor
 - for ΔIV 's up to 0.4 dl/g
 - Cooler/Deduster
- Complete System under Nitrogen
- **SSP-Technology for 100 tpd PET Chips; Technical Yarn; High IV**

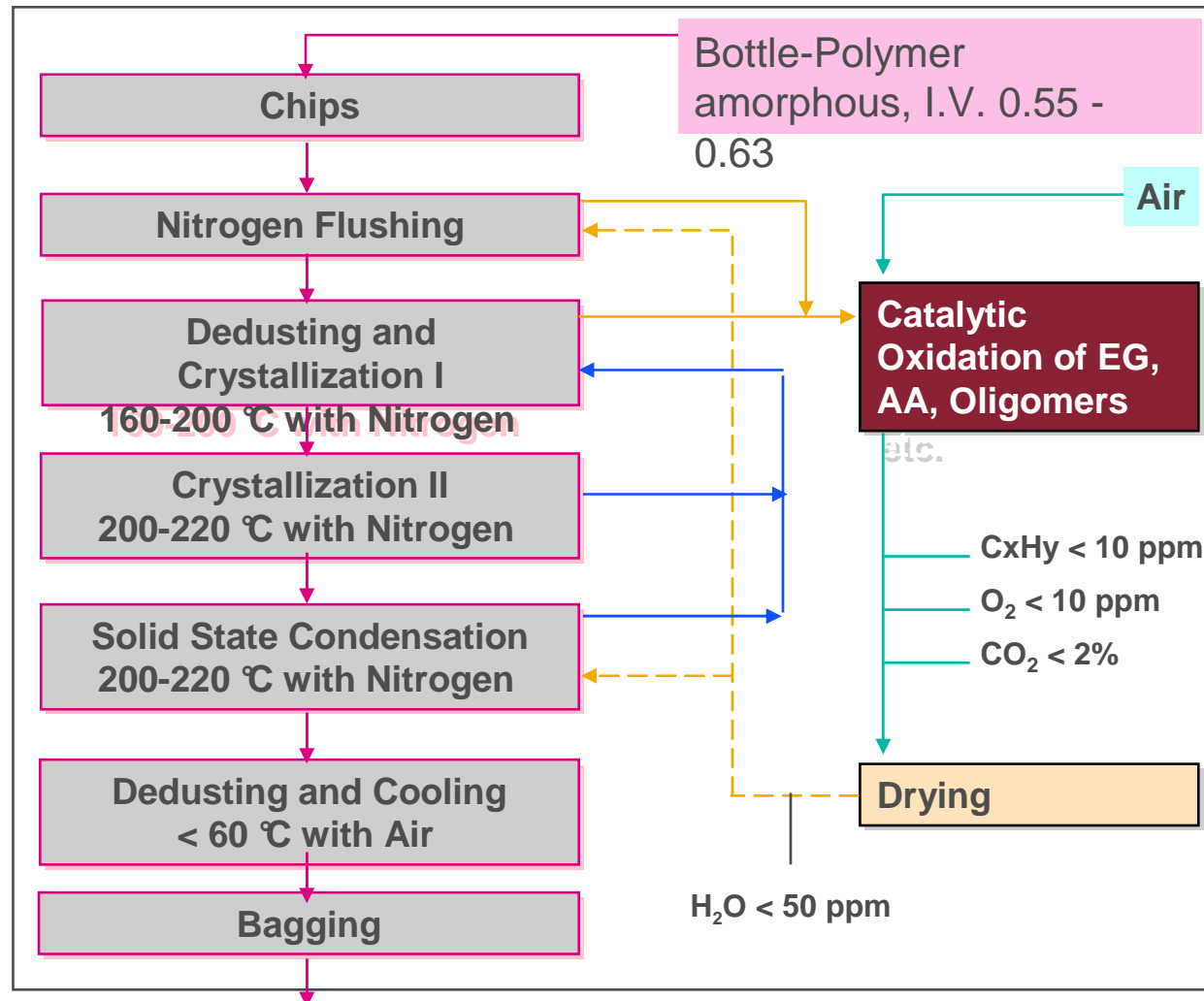

Zimmer® Polymer Technologies SSP Plant Technology

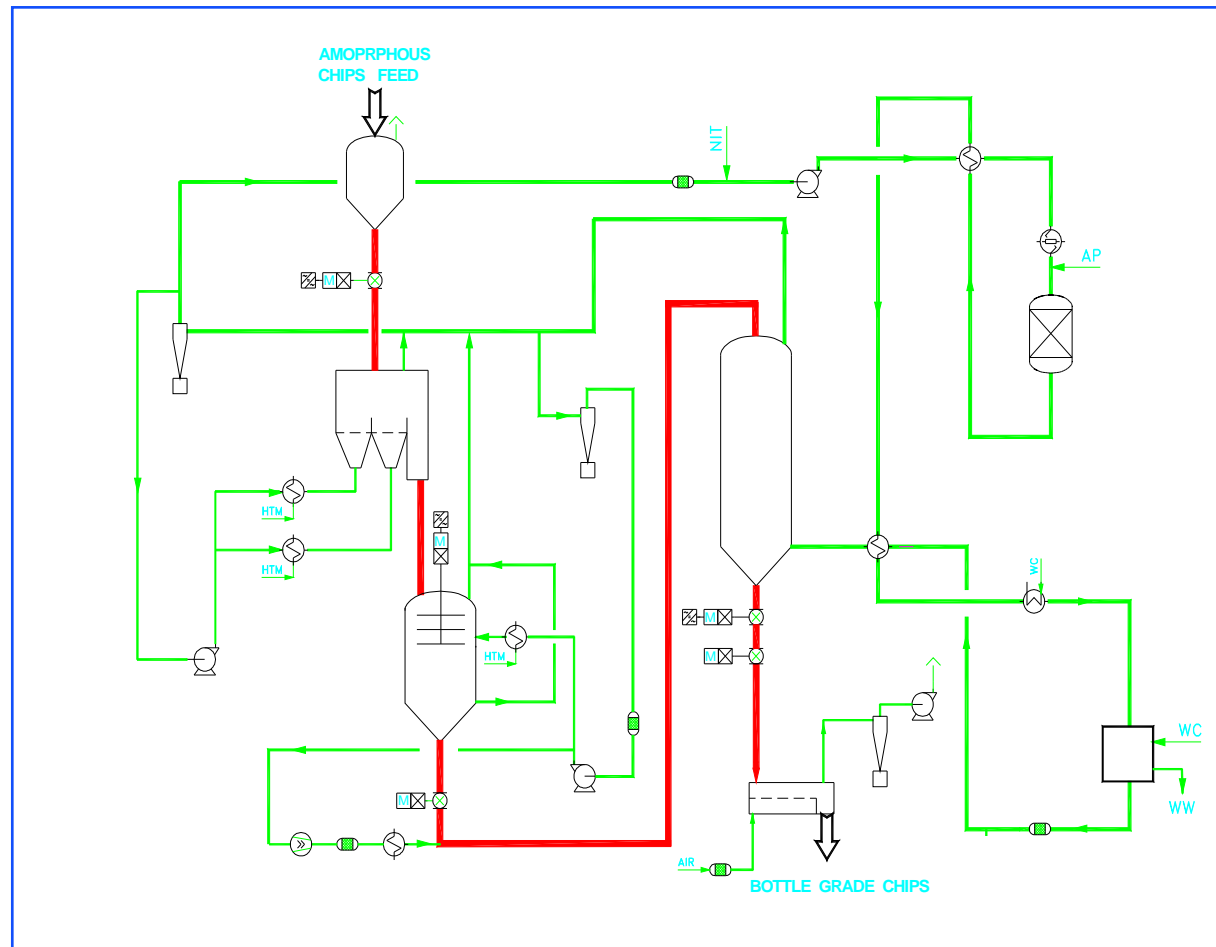

Utility Abbreviations

AP	Compressed air
HTM	Heat transfer medium
NIT	Nitrogen
WC	cooling water
WW	waste water



Zimmer Process

Low AA-content in PET-Bottles

- n ZIMMER technology - melt and solid state polycondensation ensures AA-contents of < 1.0 ppm in the PET - resin
- n low AA - rebuilt during the preform production is decisive for high bottle quality
- n the AA -rebuilt is caused by the thermally destructed vinyl ester endgroups
- n the vinyl ester endgroup concentration in the resin will increase with increased process temperature in the melt phase
- n ZIMMER's melt phase polycondensation is a low temperature process which ensures a low vinyl ester endgroup concentration
- n ZIMMER's plant design provides a low thermal stress during all processing steps
- n no oxidation damage of the polymer by avoidance of oxygen in the critical temperature range
 - excellent colour
- n optimum dedusting by fluid bed precrystallizer and fluid bed cooler after SSP
 - avoidance of fish eyes



New and proven Additive Technology for Polymers

- New catalyst systems
- New color systems
- New special additive recipes
 - Fast IR Heat up
 - Barrier
 - Specialties...
- New additive dosing systems

What's the impact?

- Significant cost reduction
- Reduced overall metal content in polymer
- Distinguished polymer quality with additional properties / new applications



PET-Polycondensation Plant Technology



References – Zimmer Technology

4-Reactor Technology (Polycondensation)



PET-Polycondensation Plant Technology



Economic 4-Reactor-Plant concept (standard version)

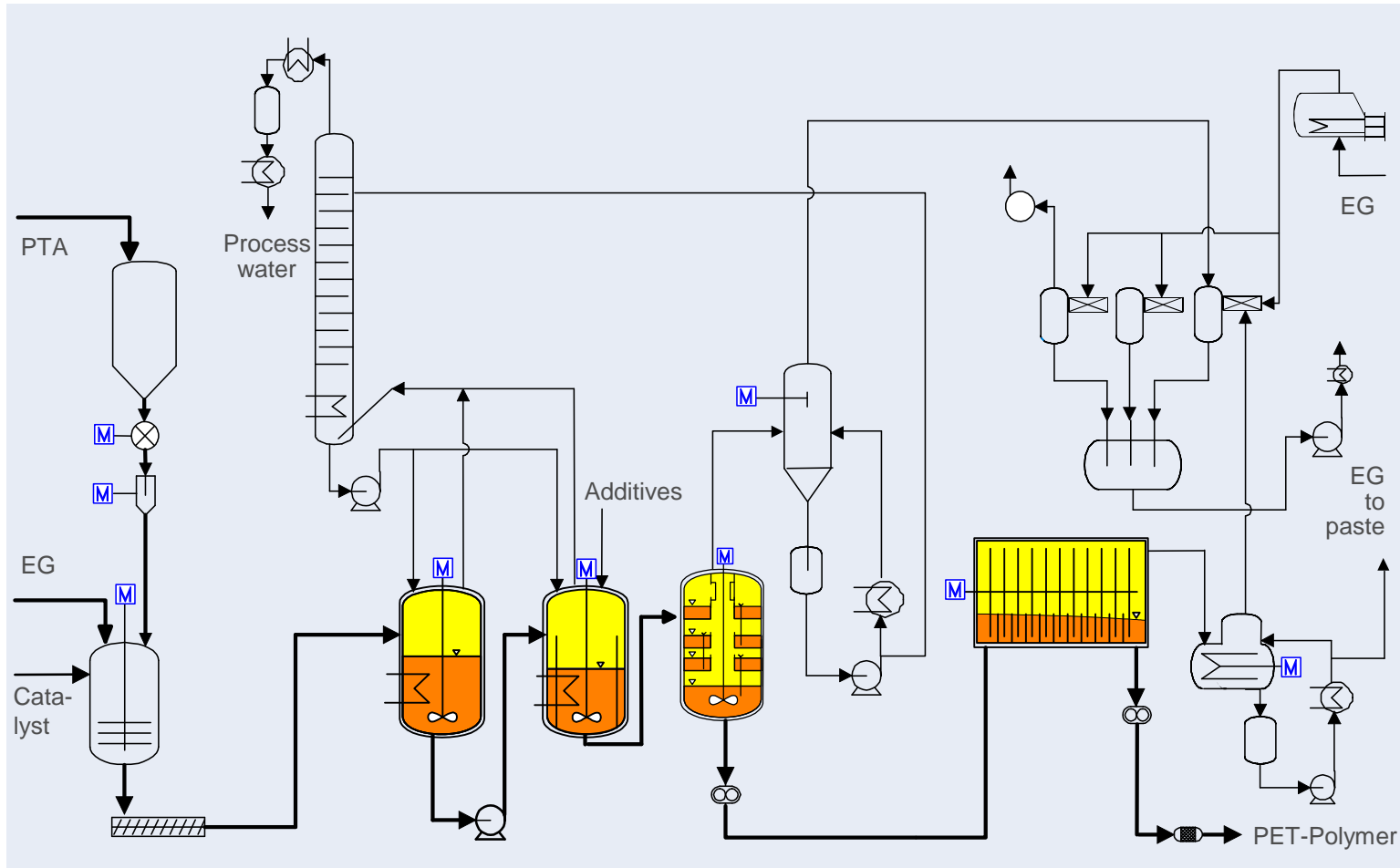

PET-Polycondensation Plant Technology



Reference List

4-Reactor process / order intake / 2000 - 2010

2000	180 tato	RAM	Tiepet / USA
2001	240 tato	Asia PET	Asia PET / Thailand
2001	400 tato	Sepco	Saudi Egyptian Petrochem Corp. / Egypt
2001	400 tato	Sepco	Saudi Egyptian Petrochem Corp. / Egypt
2002	300 tato	Nippon Resin	Mitsui Chemicals Inc. / Thailand
2002	660 tato	Jiang PES	Changzhou Plastic Group / China
2003	330 tato	Policondensation III	Brilen / Spain
2003	440 tato	Klai PET 1	Petrochemical GmbH / Lithuania
2004	440 tato	Klai PET 2	Petrochemical GmbH / Lithuania

PET-Polycondensation Plant Technology



2004	600 tato	Guan PET	Shaoxing Weiming Plastics / China
2004	630 tato	Speed	Reliance / India
2004	400 tato	Grand	Indo Rama / India
2005	440 tato	Klai-PET 3	Petrochemical GmbH / Lithuania
2005	600 tato		China
2005	330 tato	Star-PET	Indo Rama / USA
2005	440 tato		Dow Chemical / Italy
2006	660 tato		Confidential
2007	200 tato	Tver Cola	SIBUR / Revamp
2008	600 tato		Confidential



Klaus Volker Frenzel

Sales Director Polymers

Lurgi GmbH

Lurgiallee 5

60439 Frankfurt am Main, Germany

Phone: +49 69 5808 5380

Fax: +49 69 5808 5425

www.lurgi.com

E-Mail: communication@lurgi.com

